



PRCE

Synchro Electric Press Brake

Thinking Future

PRCE SYNCHRO ELECTRIC PRESS BRAKE

PRCE is a fully electric machine. Using **SYNCHRO technology** that controls **2 axes during the bending**, thus being able to compensate the axes Y1 and Y2 independently.

This system developed by RICO includes the drive through 2 high-quality ball screws with low noise, guided by two servo motors and helical gear boxes in order to guarantee the best performance and durability. This reduce all effects caused by inertia compared to similar systems of the belt. **This press brake is integrated with the highest technology coupled with a friendly use. This model is a top machine that guarantees high precision and competitiveness.**

ADVANTAGES



- Short cycle time
- Low energy consumption
- Low maintenance
- Low noise

MAIN CHARACTERISTICS

- Bending accuracy: 2,5 μ
- Approach speed: 220 mm/s
- Return speed: 220 mm/s
- Bending speed: 10/20 mm/s (the second speed is only available for some markets)
- Start/Stop function

DETAILED INFORMATION

BACK GAUGE

BGR	X	R	Z1	Z2	X5
Stroke (mm)	500 (870) 600 (970)	200	UNDER REQUEST	UNDER REQUEST	200
Speed (mm/s)	500	170	2000	2000	300
Precision (mm)	± 0,02	± 0,10	± 0,10	± 0,10	± 0,02
Type of motor	BRUSHLESS	BRUSHLESS	BRUSHLESS	BRUSHLESS	BRUSHLESS
Mechanical system	BALLSCREW	RACK	RACK	RACK	BALLSCREW

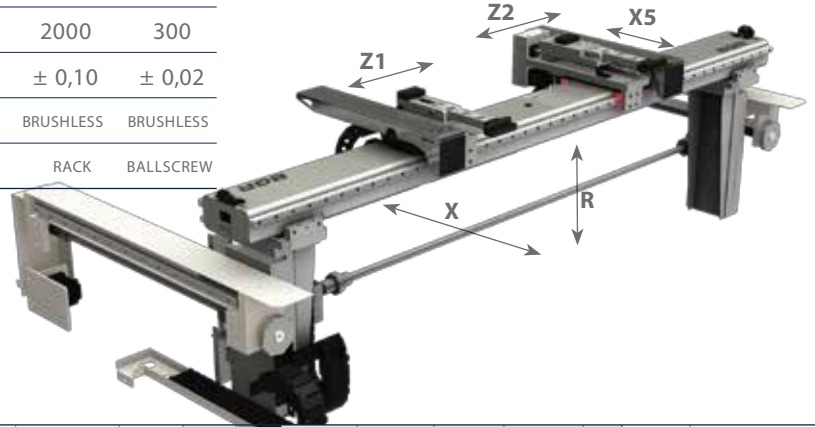

TECHNICAL SPECIFICATIONS

MODEL	Bending length mm	Tonnage Ton	Throat depth mm	Beam stroke mm	Daylight mm	Y axis speed			Back gauge stroke mm	Motor power kW	Dimensions					Aprox. weight Kg
						Fast mm/s	Bending mm/s	Return mm/s			Total length (A) mm	Total height (B) mm	Total width (C) mm	Distance between frames mm	Height under the floor mm	
PRCE 1040	1100	40	300	270	470	220	0-10/20*	220	500	6,5	1950	3050	1905	1200	0	3500
PRCE 2040	2100								600	6,5	2950	3050	1905	1600	0	5000

COMPARATIVE

