

MACHINE MODEL

BS 300 PLUS

Manual bandsaw able to cut both left and right

Short description

BS 300 PLUS is the manual bandsaws that can cut both left (up to 60°) and right (up to 45°), a versatile working tool to realize small and medium batch production, a versatile working tool that can be used either in mechanics and steelwork.



Cutting capacity at 90°	Round 255 mm. Square 230 mm. Rectangular 300x180mm
Cutting capacity at 45° right	Round 210 mm. Square 190 mm. Rectangular 200x180mm
Cutting capacity at 45° left	Round 180 mm. Square 160 mm. Rectangular 180x100mm
Cutting capacity at 60° left	Round 135 mm. Square 110 mm. Rectangular 130x100mm
Maximum capacity for full materials	Round 150 mm. Square 150 mm. Rectangular 150x150mm
Blade size.	2765x27x0,9
End-cutting bandsaw inclination	3°
Blade motor	1,5/1,8 kw
Blade speed	35/70 - 15÷110 m/min
Hydraulic unit motor power	kw 0,37
Hydraulic united tank	Lt 12
Coolant tank	Lt 20
Size	1230x1700x1750 mm
Working table height	940 mm
Weight	412kg

Features

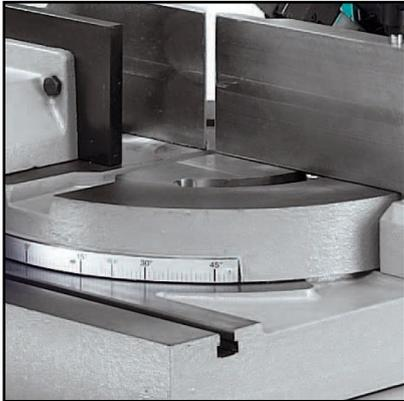

Wide working area

BS 300 PLUS is equipped with a wide diameter working area and a system of automatic easy stops at 0°, 45° and 60° left and 45° right with graduated plate to identify and set different angles.

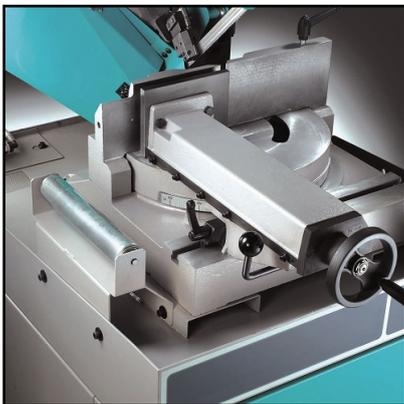

Opening vice

The vice has adjustable guides, free to move alongside the worktable, with rapid approaching and clamping.



Rigid sawframe

Machine sawframe is rigid cast-iron with tubular section, 320 mm pulleys, high blade tension at 1700 kg/cm² and to avoid an excessive strain on the blade with frontal regulation and microswitch controller.



Easy to use

Safe starting through the button on the handle with warning light to inform the use about the correct machine functioning. Coolant-tank and electropump are placed inside the floor stand.



**Electronic inverter (Optional)
ESC**

If required, the electronic inverter for variable blade speed allows the operator via keyboard to adjust the machine to be able to cut a wide range of materials and different sections. The change of speed is via inverter and it does not affect the power of the engine even at low speeds.



Minimal lubrication system (Optional) OPTIONAL

It is possible to require, for all Imet machines, the minimal lubrication system, it avoids the dispersion of refrigerant liquid typical in the use of emulsifiable oil, the life of the blade is not in any way affected.



Adapter to synchronize RTP/RTD (Optional) OPTIONAL

Adapter to synchronize the RTP/RTD table with sawframe motion.



Laser ray (Optional) OPTIONAL

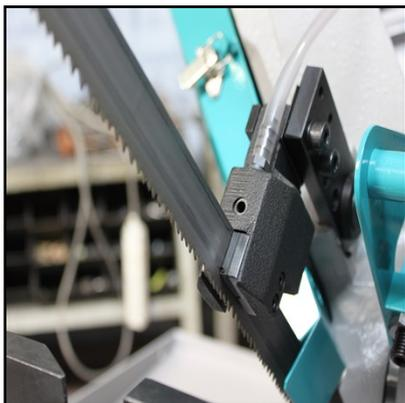

Bi-metal blade (Optional)

OPTIONAL

Size: 2765x27x0.9mm

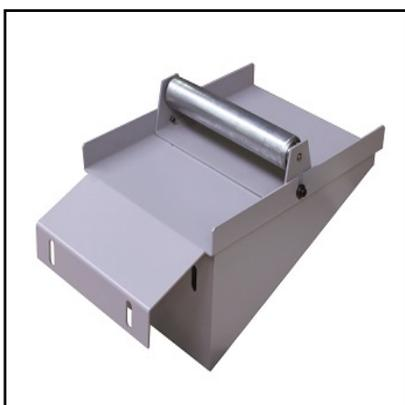

Connection element for unloading table (Optional)

OPTIONAL

Connection element for unloading table equipped with 1 roller and a slide to collect coolant.



Loading/unloading table - first element (Optional)

OPTIONAL

Loading/unloading roller table, first element, 2 m long, maximum capacity 700kg.



Loading/unloading table - following element (Optional)

OPTIONAL

Loading/unloading roller table, 2m long, following element, maximum capacity 600kg.



Unloading roller table with metric rod - first element (Optional) **OPTIONAL**

Unloading roller table with metric rod and length stop, 1st element, 2m long, maximum capacity 700kg.



Unloading roller table with metric rod - following element (Optional) **OPTIONAL**

Unloading roller table with metric rod and length stop, following element, 2m long, maximum capacity 600kg.



Unloading table: digital reading, manual positioning (Optional) **OPTIONAL**

RTD2LW30 - unloading table with digital reading and manual positioning, measurement length 2m, capacity 700kg
RTD4LW30 - unloading table with digital reading and manual positioning, measurement length 4m, capacity 1300kg
RTD6LW30 - unloading table with digital reading and manual positioning, measurement length 6m, capacity 1900kg



Unloading table: motorized length stop, lengths select. (Optional) **OPTIONAL**

RTP3W30 - Unloading table with motorized length stop and selection of the lengths via keyboard, 3m, 1300kg.
RTP6W30 - Unloading table with motorized length stop and selection of the lengths via keyboard, 6m, 1900kg.
RTP9W30 - Unloading table with motorized length stop and selection of the lengths via keyboard, 9m, 2700kg



sawing technology

IMET SPA
Località tre fontane, 6 - 24034
Cisano Bergamasco (BG) Italy
Tel +39 035 4387911 | Fax +39 035 787066
imet@imetsaws.com
www.imetsaws.com

BS 300 PLUS



Pair of vertical roller 300mm (Optional)

OPTIONAL

Pair of vertical rollers 300 mm made in steel, max 2 pairs for each element 2m long. To use without rollers covers.